

# ***SERVICE NEWS***

VOL. 10, NO. 3, JULY—SEPTEMBER 1983

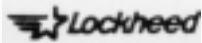

**RUDDER  
THRUST  
BEARING  
SERVICING**



# SERVICE NEWS

A SERVICE PUBLICATION OF  
LOCKHEED-GEORGIA COMPANY  
A DIVISION OF  
LOCKHEED CORPORATION

*Editor*

Charles I. Gale

*Associate Editors*

Daniel E. Jolley  
James A. Loftin  
Steve Palmer

*Art Direction & Production*

Bill Campbell

Vol. 10, No. 3, July-September 1983

CONTENTS

2 **Focal Point**

P. E. Storey  
Program Manager  
C-130/L-100 Engineering

3 **Controlling Rudder Thrust Rearing Wear**

Proper lubrication is the key to long bearing life.

8 **Chemical Control of Fuel Tank Infestation**

Biocidal shock treatments keep microbial growth in check.

10 **Solid-State Oil Temperature Control Thermostats**

Oil cooling system operation reflects thermostat changes.

14 **HF Antenna Wire Breakage Sealing out corrosion keeps antenna wires on the job.**

Cover: Cutaway view of the Hercules aircraft empennage.

Published by Lockheed-Georgia Company, a Division of Lockheed Corporation. Information contained in this issue is considered by Lockheed Georgia Company to be accurate and authoritative. It should not be assumed, however, that this material has received approval from any governmental agency or military service unless it is specifically noted. This publication is for planning and information purposes only, and it is not to be construed as authority for making changes on aircraft or equipment, or as superseding any established operational or maintenance procedures or policies. The following marks are registered and owned by Lockheed Corporation: "Lockheed", "Hercules", and "JetStar". Written permission must be obtained from Lockheed-Georgia Company before republishing any material in this periodical. Address all communications to Editor, Service News Department 64-22 Zone 278, Lockheed-Georgia Company, Marietta, Georgia, 30063. Copyright 1983 Lockheed Corporation.

## Focal Point

### Teamwork and Communications

It is a real pleasure to be part of this issue of Service News magazine. We in Lockheed engineering are proud of the Hercules aircraft and would like to thank you, the people who keep her flying, for helping this remarkable airplane achieve such a long and outstanding record. Flying and maintaining airplanes always requires a dedicated team, and we believe that the unique success of the Hercules represents modern aviation's best and longest-running demonstration of what real teamwork between manufacturer and operator can accomplish.



P. E. Storey

Nothing is more vital to effective teamwork than well-established and properly utilized lines of communication. This publication, for example, is an integral part of the Hercules aircraft communications network. It makes its contribution by ensuring that a broad range of general information on technical subjects is readily available to all members of the Hercules "team" (To see just one area where this can be important, we have only to recall that many changes have been made to the airframe, power plants, functional systems, and individual components of the Hercules aircraft since the first flight of the YC-130 in August of 1954. While safety items and other matters that should receive the immediate attention of Hercules operators are covered in service bulletins, we have found that Service News is an excellent medium for introducing and describing the various improvements and evolutionary refinements that have become part of the Hercules aircraft over the years.

One such improvement that has been incorporated into the aircraft relatively recently is the solid-state oil temperature control thermostat. The article beginning on page 10 offers a complete description of this new thermostat and its operational characteristics. I think this article is a good example of how our C-130/L-100 design engineers try to select the most appropriate mode of communication in responding to inquiries of general interest that have been received from operations and maintenance organizations in the field.

Another area of vital interest to everyone involved in the Hercules aircraft program is maintenance. Our engineering staff, the service representatives of the Customer Service organization, and the operators who work directly with the aircraft regularly come up with hints and maintenance ideas that can be beneficial to all. Here again, it is only by bringing these ideas to the attention of others that they become truly useful. Several items of this type are presented in the other articles in this issue.

Open lines of communication are indispensable to effective teamwork no matter what the undertaking. The Hercules team - all of us from the design engineer in the factory to the maintenance specialist in the field - have shown for nearly thirty years what good communications can do when professional people work together on a quality product. This is a tradition to build on. Remember that we in Lockheed engineering are part of your team. We urge you to contact us through your local Lockheed service representative directly any time we can assist you in getting all the performance and service out of your Hercules airlifters that we build into them.

Sincerely,

P. E. Storey  
Program Manager  
C-130/L-100 Engineering

## PRODUCT SUPPORT

LOCKHEED-GEORGIA COMPANY  
MARIETTA, GEORGIA 30063

T. J. Cleland

Director

CUSTOMER  
SERVICE

INTEGRATED  
LOGISTICS SUPPORT

CUSTOMER  
SUPPLY

A. H. McCrum  
DIRECTOR

J. L. THURMOND  
DIRECTOR

M. M. HODNETT  
DIRECTOR



## Controlling Rudder Thrust Bearing Wear

Proper operation of the rudder is essential to the controllability of any aircraft, but in the case of the Hercules aircraft, which is routinely called upon to perform complex missions at a great variety of speeds and altitudes, a smoothly functioning rudder is of particular importance.

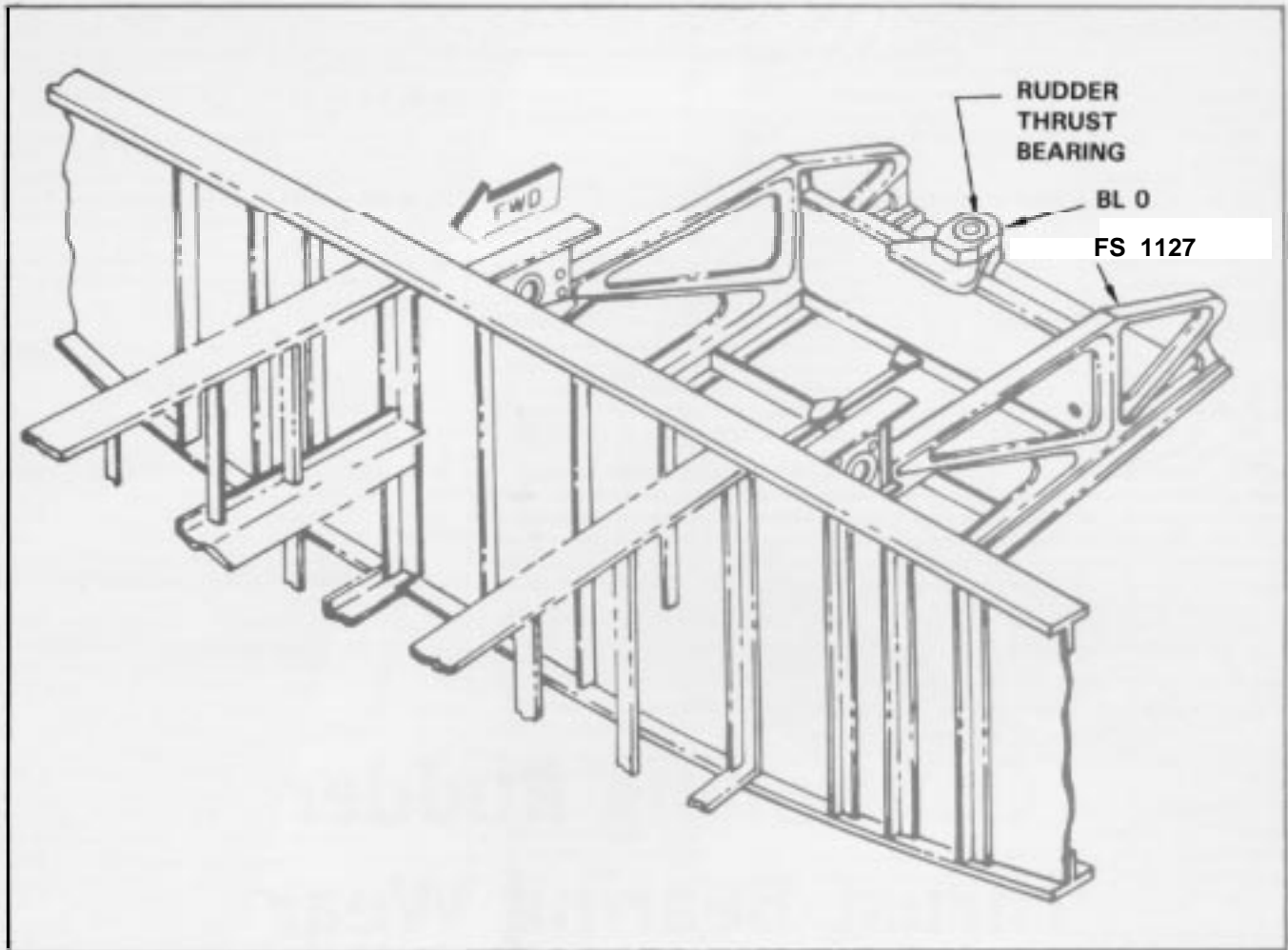

**Figure 1. Rudder thrust bearing location.**

Lockheed has recently received reports of problems with the operation of the rudder on some Hercules aircraft. There are indications that lack of regular servicing may have played a role in many of these cases. Since the rudder is generally a trouble-free item from a maintenance standpoint, its servicing may not always receive the attention it deserves.

**Effects of Thrust Bearing Wear**

The complaints included such things as jerky, erratic, or sluggish rudder movement, particularly at low airspeeds, and a tendency for the aircraft to “hunt” about the vertical axis (yaw) when the autopilot was engaged. Investigation showed that in most of the aircraft where these conditions were noted, the large roller bearing that supports the weight of the rudder at its base turned out to be seriously worn. Replacement of the affected P/N C-12 or DA12-38AQ rudder thrust bearing (Figure 1) cleared the discrepancies.

Subsequent study of the worn bearings by Lockheed

yielded strong evidence that the single most important factor in their premature demise was inadequate lubrication. The bearings had been allowed to run dry, and the resultant metal-to-metal contact destroyed the bearing surfaces in short order.

Once the nature of the problem had been established, Lockheed issued Service Bulletins 82-504 and 382-27-26, discussing these findings and outlining a recommended course of action to prevent premature rudder thrust bearing wear from occurring.

The service bulletins also provide helpful information concerning replacement of the bearing should damage already be present. Since the information covered in these documents has broad applicability and can be of significant value in reducing maintenance downtime wherever the Hercules aircraft is flown, we would like to review the salient points here.

**Servicing Recommendations**

In aircraft where the rudder appears to be function-

ing properly and none of the symptoms of rudder thrust bearing wear described above are present, the only immediate action recommended is to give the thrust bearing an extra lubrication as a precautionary measure. T.O. IC-130A-6WC-15 specifies that the rudder thrust bearing is to be lubricated with MIL-G-XI322 general-purpose grease, or the equivalent, at each minor and major inspection. In the case of commercial Hercules aircraft, the service bulletins referenced above recommend an immediate extra application of lubricant and then lubrication at intervals of 1800 flight hours or 365 days, whichever occurs first.

This should be sufficient as far as routine servicing is concerned, but it is very important that the lubrication procedure be carried out conscientiously, and that every effort is made to ensure that an adequate amount of approved lubricant actually enters the bearing without damaging the bearing seals.

Lockheed also recommends that the rudder thrust bearing be routinely replaced whenever the rudder is removed for some reason in the course of a maintenance activity. The cost of the part is minimal compared to the time and effort required to get at it, and installing a new one whenever the rudder is already out of the way will help reduce the chances that the thrust

bearing will suddenly need to be replaced at a less convenient time.

### Thrust Bearing Replacement

If the condition of a rudder thrust bearing has deteriorated to the point that it is causing erratic rudder operation, no amount of extra lubrication will restore normal operation. Permanent damage to the bearing has probably already occurred, and the only solution is to replace it.

The first step in removal and replacement of the rudder thrust bearing is to remove the rudder and rudder counterbalance assembly from the aircraft. The applicable authorized maintenance manual for your airplane contains the information necessary to complete these tasks. It is essential that you strictly observe all safety precautions set forth in the maintenance manual to prevent possible injury to yourself or others while performing maintenance on the rudder and associated components. Be sure to remove all hydraulic and electrical power from the airplane before you begin.

Once you have removed the rudder and rudder counterbalance assembly from the aircraft, move the rudder torque arm to one side. Next, remove the cotter

**Figure 2. Counterbalance, torque arm, and rudder support cone fitting with associated hardware.**

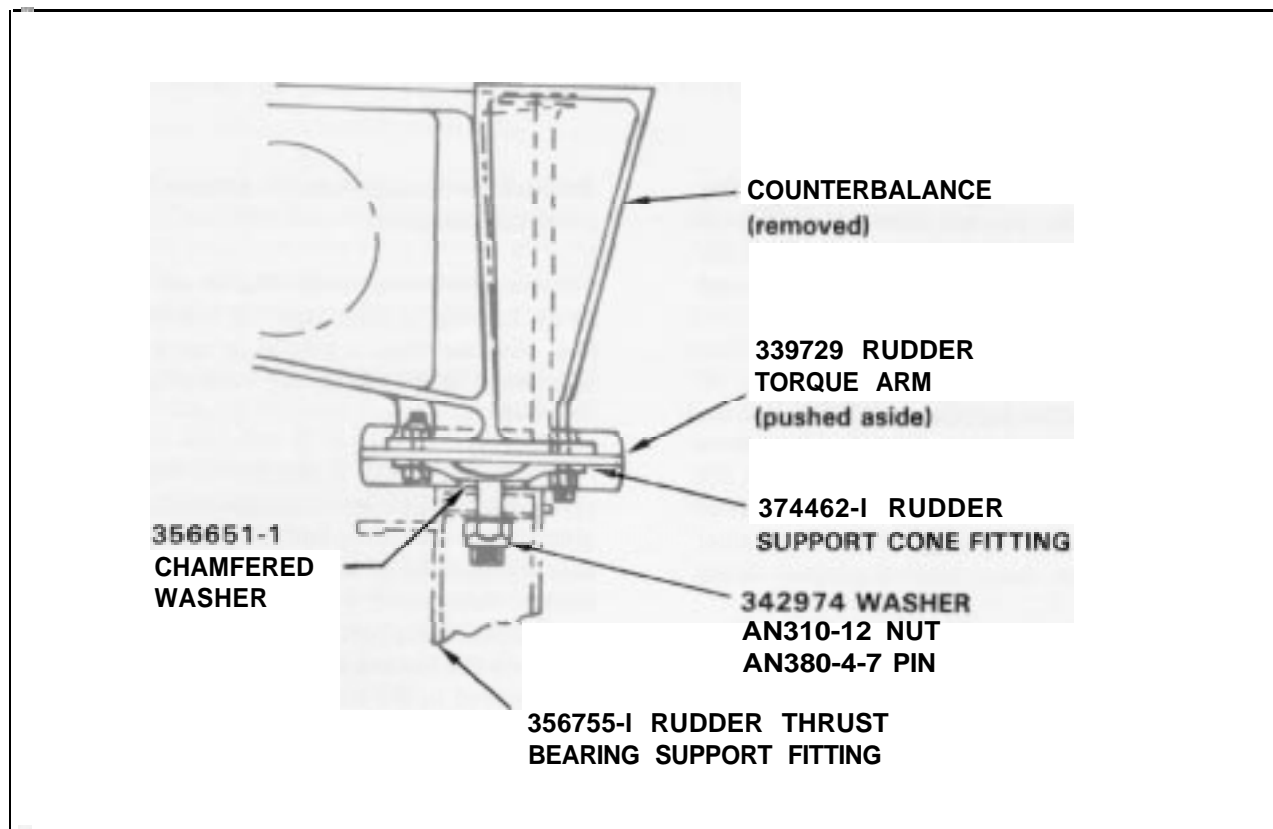

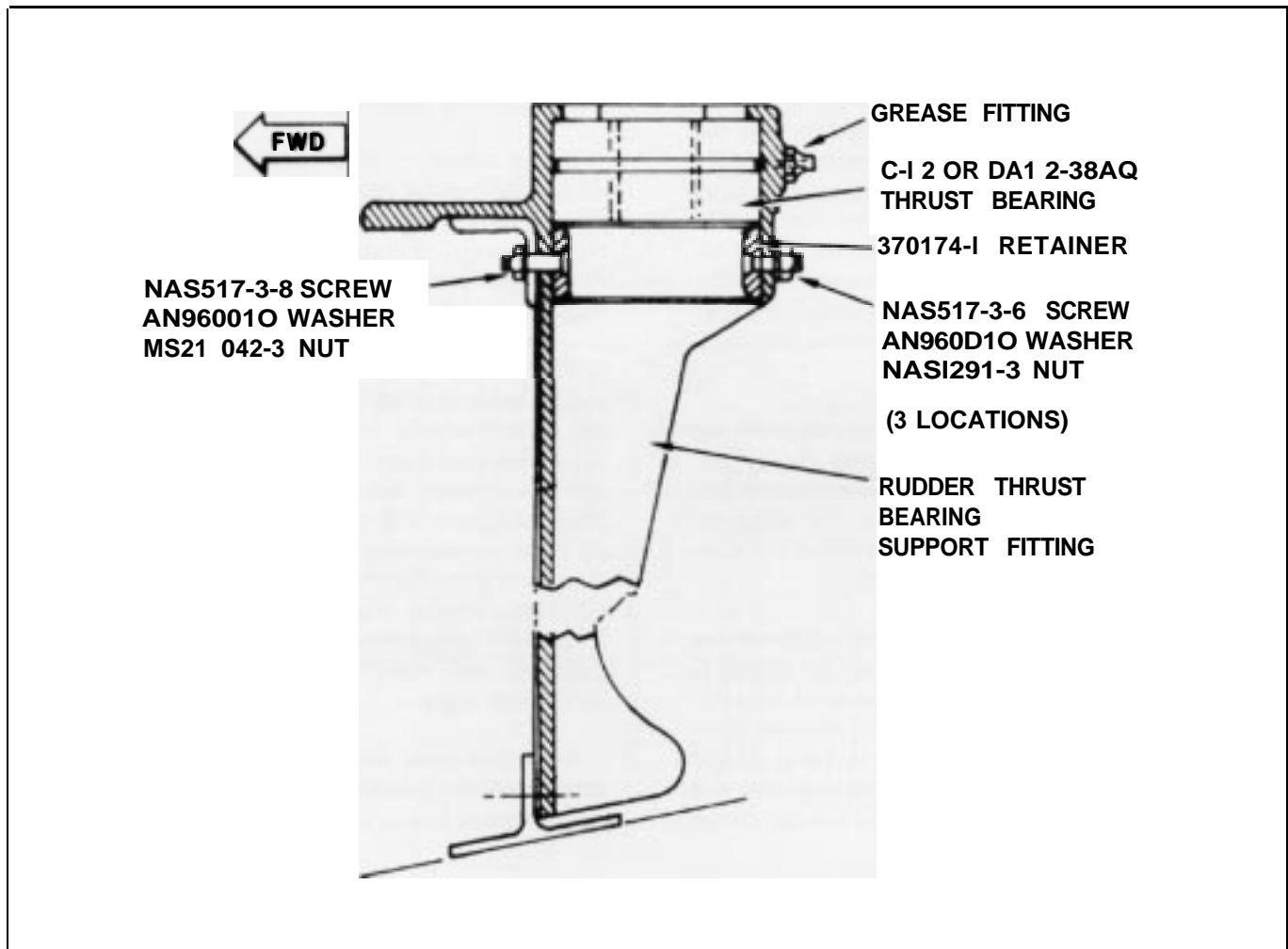

Figure 3. Rudder thrust bearing installation.

pin, the nut, and the P/N 342974 thrust bearing washer from the rudder support cone fitting (Fig. 2). Examine the nut and washer for signs of damage, corrosion, or wear. If they are sound, they may be saved for reinstallation.

Now remove the rudder support cone fitting and the thrust bearing chamfered washer, P/N 356651-1, from the rudder thrust bearing support fitting. Keep the cone fitting and washer so that they can be reinstalled later. Locate the roller bearing and the retainer mounted in the rudder thrust bearing support fitting (Figure 3).

Next remove and put aside the four nuts, washers, and screws from the thrust bearing retainer. Be sure to keep the nut, screw, and washer removed from the front of the retainer in a separate place from the other retainer hardware; the front screw is longer than the other three, and uses a different washer and nut.

Remove the retainer from the support fitting, and save it for reinstallation.

Press firmly with your fingers on the top of the thrust bearing to disengage the bearing from the fitting. You may find it helpful to use a drift pin and a hammer to lightly tap the top outer edge of the bearing to loosen it.

Before you install a new thrust bearing, flush the grease fitting with new lubricant to remove any caked grease from the fitting and the grease path; then use a soft cotton cloth to wipe out the inside of the support fitting. Next, insert a new bearing up into the rudder thrust bearing support fitting. Use your fingers to push firmly on the bottom side of the bearing until the bearing is seated in the support fitting.

#### Reassembly

Install the bearing retainer in the bottom of the sup-



**Airdrop:** a time when the smooth and precise operation of all flight controls plays a crucial role.

port fitting and secure the retainer, using the four screws, nuts, and washers that were put aside earlier. Be sure that the longer of the four screws and its accompanying nut and washer are installed through the forward side of the retainer (Figure 3).

After you have the retainer in place, install the original cone fitting by inserting it down through the bearing. Be sure that the P/N 356651-1 chamfered washer is inserted onto the shaft of the cone fitting so that the washer rests between the fitting and the bearing. After this step, insert the P/N 342974 thrust bearing washer onto the shaft of the cone fitting and secure the whole assembly with the nut that was originally installed. You should obtain a new cotter pin from supply and install it through the hole in the threaded end of the rudder support cone fitting.

It is a good idea at this stage of the job to check that the four rudder hinge pins and hinge bearings are in a good state of repair.

Before you install the rudder and the counterbalance assembly, thoroughly lubricate the new bearing with MIL-G-81322 lubricant via the grease fitting located on the aft side of the support fitting (Figure 3). Be careful not to dislodge the bearing seals by exerting excessive pressure on the trigger of the grease gun. Slight pressure is all that is necessary to provide sufficient lubrication. After you lubricate the bearing, you can complete the job by reinstalling the rudder and the counterbalance assembly as outlined in the appropriate flight controls technical manual.





It isn't every day that a new product appears which combines several important virtues in one convenient package, but it happened in the case of a chemical known as ethylene glycol monomethyl ether. This compound, which is more commonly referred to by one of its several trade names (see table, page 9) or as MIL-I-27686 anti-icing inhibitor, was originally developed by Phillips Petroleum Company as an anti-icing agent for aircraft fuel tanks. Added to turbine fuel, MIL-I-27686 does indeed reduce the hazards of icing in aircraft fuel systems. But it can do other useful things as well. MIL-I-27686 acts to depress the flash points of such volatile fuels as JP-4, and it also kills the microorganisms that can cause corrosion of aircraft structure and blockage of fuel systems.

### Control Strategies

It is this last feature of its activity that will be of interest to us here. Military turbine fuels such as JP-4, JP-5, and JP-8 have all contained MIL-I-27686 for a number of years. Its biocidal properties, together with good housekeeping practices at fuel storage facilities, have enabled U.S. military operators to keep the problem of microbial growth in the fuel tanks of their aircraft well under control.

But turbine fuels furnished with MIL-I-27686 anti-

icing additive usually cost more, and their availability is limited in certain areas. As a result, many other Hercules aircraft operators do not regularly use fuels that contain this ingredient. Some rely on good housekeeping at their fuel supply facilities and on the automatic water extraction systems built into the fuel tanks of their aircraft. This approach has been successful for some operators, but over the long run it can be risky.

Another group of operators also use fuels that contain no biocidal anti-icing additives, but manage to control microbial infestation of their fuel tanks quite effectively nonetheless. They do it by periodically adding a biocide to the fuel they use, a process commonly called shock treatment. When prudently applied and used in conjunction with good fuel storage housekeeping, this method can be effective in controlling microbial growth. The biocidal shock treatment is popular among air transport operators, not only because of the relatively low cost, but also because it can be administered with little extra effort when the airplane is out of service for periodic maintenance, such as at the letter checks.

Unfortunately, improper employment of the shock treatment method can be both ineffective in killing microorganisms and possibly damaging to fuel cells,



sealants, or power plants. With these concerns in mind, we would like to suggest some guidelines for the use of biocides in the fuel tanks of Hercules aircraft, in particular when they are used in conjunction with the shock treatment method of infestation control.

### Treatment Techniques

There are two different products which are commonly used to shock-treat microbial growth in the fuel tanks of turbine-powered aircraft. One we have already mentioned. MIL-I-27686 is approved for continuous use in the fuel tanks of Hercules aircraft, but it also works well as a shock treatment. When it is to be used in this way, MIL-I-27686 should be mixed with fuel at a concentration of 1 to 1.5 gallons of additive to 1000 gallons of fuel.

The other product that has proven effective was developed specifically as a biocide and has no significant anti-icing or flash point modifying effects. It is called Biobor JF, and it is manufactured by Standard Oil Company (Ohio), Midland Bldg., Cleveland, OH 44115. Biobor JF contains boron, and boron is an element which may affect the longevity of turbine blades if present in fuel in sufficient quantity. The use of Biobor JF is therefore subject to certain restrictions imposed by the engine manufacturer. It may be used on an intermittent basis, such as would be the case for a shock treatment, provided that the concentration used is such that the fuel contains no more than 20 parts per million elemental boron. A safe concentration is about 12.5 ounces of Biobor JF for each 1000 gallons of fuel.

### Precautions and Recommendations

No matter which of the two recommended biocidal additives is selected for use in a shock treatment program to control fuel tank microbial infestation, certain precautions apply:

☐ Make sure that the fuel tank being treated is at least 10% full of fuel before introducing the biocide. A high concentration of additive can be damaging to elastomeric substances such as sealants and rubber.

■ Additives should not be poured directly into the tanks in concentrated form, but should be metered into the fuel slowly as the tank is being fueled so as to blend the fuel and additive homogeneously.

☐ Use the recommended mixture of additive and fuel. As noted above, too high a concentration of MIL-I-27686 can harm elastomeric fuel system components. On the other hand, too low a concentration of this inhibitor in the fuel may act as a nutrient for the microorganisms instead of a biocide. Biobor JF must

also be carefully measured. Too much would expose the engines to excessive boron. Too little will result in unsatisfactory biocidal activity.

■ Allow the treated fuel to stay in the tank long enough to kill the microbial invader. Dwell time should be a minimum of 24 hours; preferably 48 to 72 hours for optimal results. A 24-hour contact with the treated fuel will kill up to 98% of the microorganisms.

■ Perform the shock treatment on a regular schedule. Operational conditions will vary among operators, which means that some aircraft will be more subject to infestation than others. Accordingly, the frequency of treatment required will vary from one geographical region to another. As a rule of thumb, the shock treatment should be administered about every three to four months.

■ When the fuel tanks are given regular treatments of biocide, the aircraft can be returned to service with treated fuel. However, the fuel should be removed if the concentration and quantity of dead microbial residue are considered sufficient to lead to blockage of the fuel system. Anytime that the contamination is sufficient to require fuel removal, the affected tank should be flushed with fresh fuel or treated fuel before being refueled. If the contamination in the tank is deemed too much to remove by flushing, the tank should be opened, cleaned, and sterilized in accordance with the procedures in the appropriate fuel system maintenance instructions.

Product	Manufacturer and Address
Phillips PFA 51MB	Phillips Petroleum Co. Bartlesville, OK 74004
Frost	PPG Industries Inc. One Gateway Center Pittsburgh, PA 15222
Shell Methyl Oxidol FA-4	Shell Chemical Co. One Shell Plaza Houston, TX 77001
UCAR 500	Union Carbide Corp. 270 Park Avenue New York, NY 10017
Dow Anti-Icing Additive	Dow Chemical Co. 2020 Dow Center Midland, MI 48640

Additional information on this subject can be found in two articles which appeared previously in this publication: "Controlling Microbial Growth in Aircraft Fuel Tanks," Volume 2, Number 2 (April - June 1975) and "Maintenance of Integral Fuel Tanks," Volume 9, Number 4 (October - December 1982).

**SERVICE NEWS**

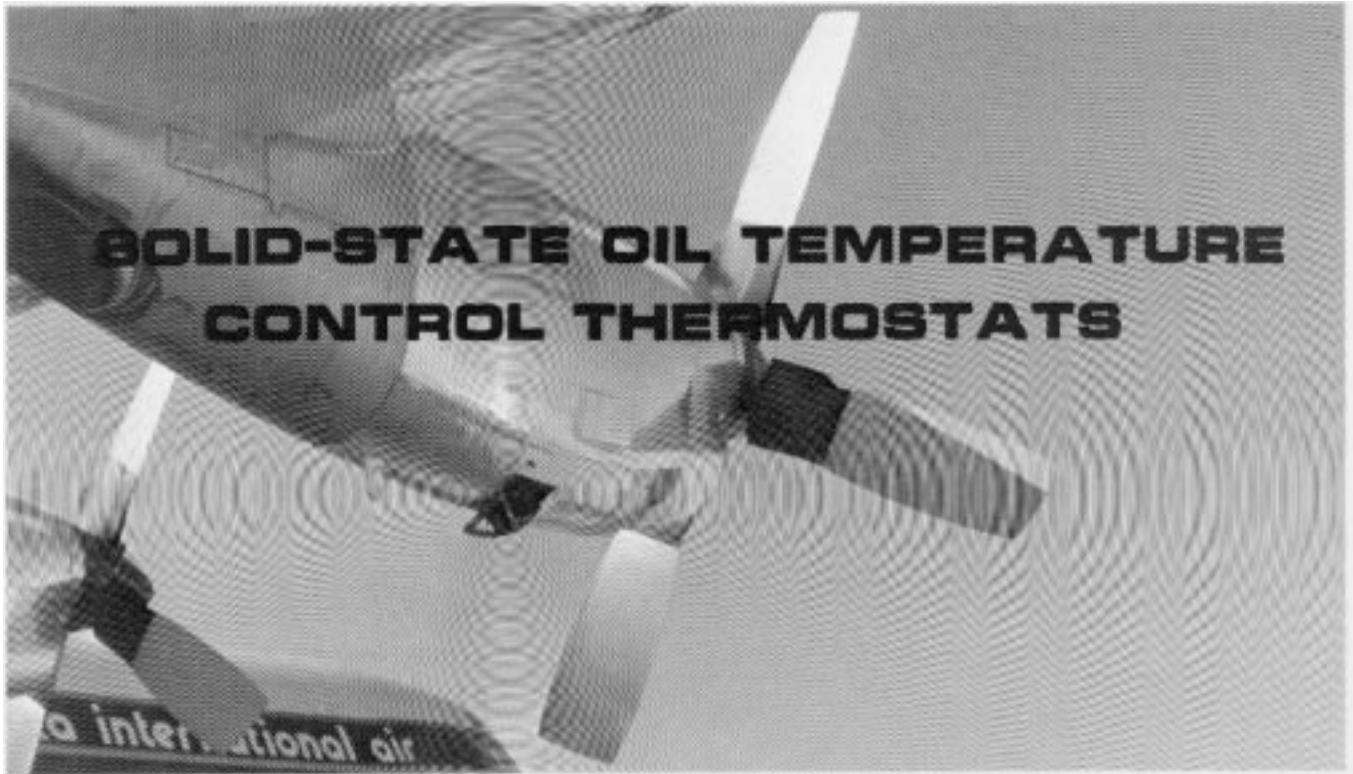

Each engine nacelle of the Hercules aircraft is **pro**vided with a movable oil cooler flap. Its purpose is to regulate the flow of air through an oil cooler assembly. The oil cooler flap is controlled by an oil temperature control thermostat, which is located between the outlet of the oil cooler and the engine oil tank (Figure 1). A few years ago, Lockheed introduced a reliable new solid-state oil temperature control thermostat, built by Dataproducts New England, to be used as a replacement for the glass-mercury type thermostat that was then in use. This led to confusion on the part of a few of our operators because the solid-state thermostat changed some of the operating parameters of the oil cooling system. In this article we will discuss some of the changes in system performance, and pass along a helpful recommendation made by Lockheed engineering concerning its operation.

### **Thermostat Temperature Settings**

The glass-mercury type oil temperature control thermostat was designed to maintain oil temperature between 79.5°C and 82°C. In reality, this type of thermostat actually controlled oil temperature at approximately 85°C, which is the upper limit of the normal oil temperature range of 60°C to 85°C. Since the glass-mercury thermostat maintained oil temperature at the upper limit, there was no margin of error for any problem, such as component aging, that caused even a slight temperature increase. For this reason,

many glass-mercury thermostats were removed because they had begun to control the oil temperature at 86°C, which is out of the normal range. Since the glass-mercury thermostat control point was set so close to the upper temperature limit and this sometimes led to problems, Lockheed decided that the new solid-state thermostat should be set to control oil temperature closer to the middle of the normal oil temperature range of 60°C to 85°C. The new thermostat was therefore designed to maintain oil temperature between 69.5°C and 75°C. By setting the thermostat to control oil temperature at the middle of the normal range, thermostat replacement due to slight increases in oil operating temperatures became unnecessary. A second reason for lowering the control temperature is that the cooler the engine oil is controlled, the lower the engine overhaul cost will be because of a reduction in oil coking.

### **Changes in System Performance**

One consequence of lowering the oil temperature control point is that the operation of the oil cooler flap is different from what it is when the cooler flap is controlled by a glass-mercury thermostat. This means that if an aircraft has both types of thermostats, there may be differences noted in the automatic operation of the oil cooler flaps. There have even been instances when oil cooler flaps controlled by a solid-state thermostat would stay open after takeoff, while the flaps controlled by glass-mercury thermostats started moving

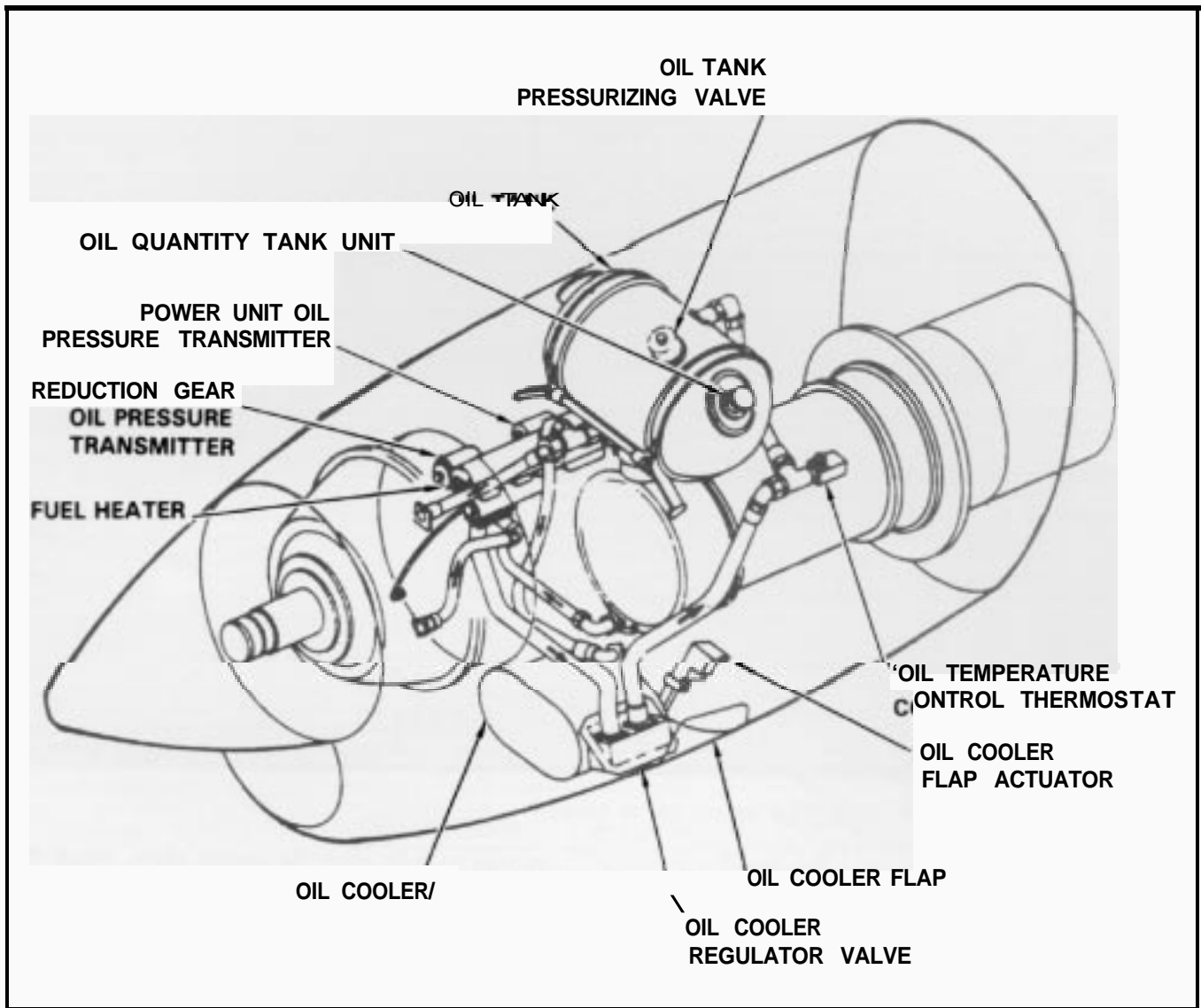

Figure 1. Engine oil supply system.

toward the closed position.

One such occurrence involved a Hercules aircraft equipped with three glass-mercury thermostats and one solid-state thermostat. On the ground, with all oil cooler flap switches in automatic, the cooler flaps were full open (Figure 2). As power was applied for takeoff, the oil cooler flaps that were controlled by the glass-mercury thermostats moved toward the closed position and the oil temperatures stabilized at 85°C. The cooler flap controlled by the solid-state thermostat remained open until the oil cooler flap switch was placed to CLOSE. When the flap reached 40%, the switch was placed back to AUTOMATIC, at which time the flap continued to close to about 5% open. With this oil cooler flap at 5%, the oil temperature stabilized at 76°C.

The reason that the solid-state thermostat-

controlled oil cooler flap did not automatically close in this case can be traced to the interaction of the oil temperature control thermostat and the thermostatic bypass and relief valve assembly in the oil cooler regulator valve.

The oil cooler regulator valve directs oil into or bypasses oil around the oil cooler, depending on the temperature of the oil (Figure 3). When the temperature of the oil is less than 54°C (+/-3°), the thermostatic bypass and relief valve is fully open. This allows most of the oil flowing into the oil cooler regulator valve to bypass the oil cooler. At approximately 54°C, the bypass valve starts to close and should be fully closed when the oil temperature reaches approximately 68°C. With the bypass valve fully closed, all the oil entering the regulator valve goes through the oil cooler.



Figure 2. Oil cooler flaps-shown full open prior to takeoff.

### The Heat Sink Effect

Notice, however, that the 68°C closing temperature of the thermostatic bypass and relief valve is only 1.5°C below the low end of the oil temperature control thermostat closing temperature (69.5°C). With the “fully closed” temperature of the bypass valve so close to the low end of the closing temperature of the oil temperature control thermostat (69.5°C), the bypass valve may not fully close to force all oil through the oil cooler. The bypass valve does not close fully because the oil cooler acts as a heat sink. This heat sink effect allows the thermostatic bypass and relief valve to respond as though the oil temperature were cooler than it actually is. Since the bypass valve is not fully closed, oil that is hotter than the closing temperature of the bypass valve reaches the oil temperature control thermostat. As long as the temperature of the oil reaching the oil temperature control thermostat is greater than 69.5°C, the cooler flap will remain **open**. This keeps full air flow moving through the oil cooler, which further aggravates the heat sink effect.

### Initiating Automatic Operation

This situation can be alleviated by manually closing the oil cooler flap to raise the temperature of the oil

enough to fully close the bypass valve, which then forces all the oil through the cooler and removes the heat sink effect. With the oil cooler warmed up, the system will work normally in the automatic mode; i.e., during subsequent takeoffs, the cooler flap will move closed along with the glass-mercury thermostat controlled oil cooler flaps, albeit to a few percent more open position.

Lockheed engineering’s recommendation is therefore the following: if a solid-state thermostat-controlled oil cooler flap does not automatically close after takeoff, place the oil cooler flap switch to **CLOSE** until the flap reaches 40% and then put the switch back to **AUTOMATIC**. The **oil** cooler flap will continue to close until it reaches approximately 5%; the oil temperature should stabilize at approximately 76°C.

Under certain circumstances it may require a little monitoring to obtain optimum performance from the oil cooler flaps with the solid-state thermostats installed, but the advantage of greater system reliability, plus the added benefit of maintaining oil temperatures at a lower level, will far outweigh any transient inconvenience that may be experienced as an indirect result of the modernization of the system.



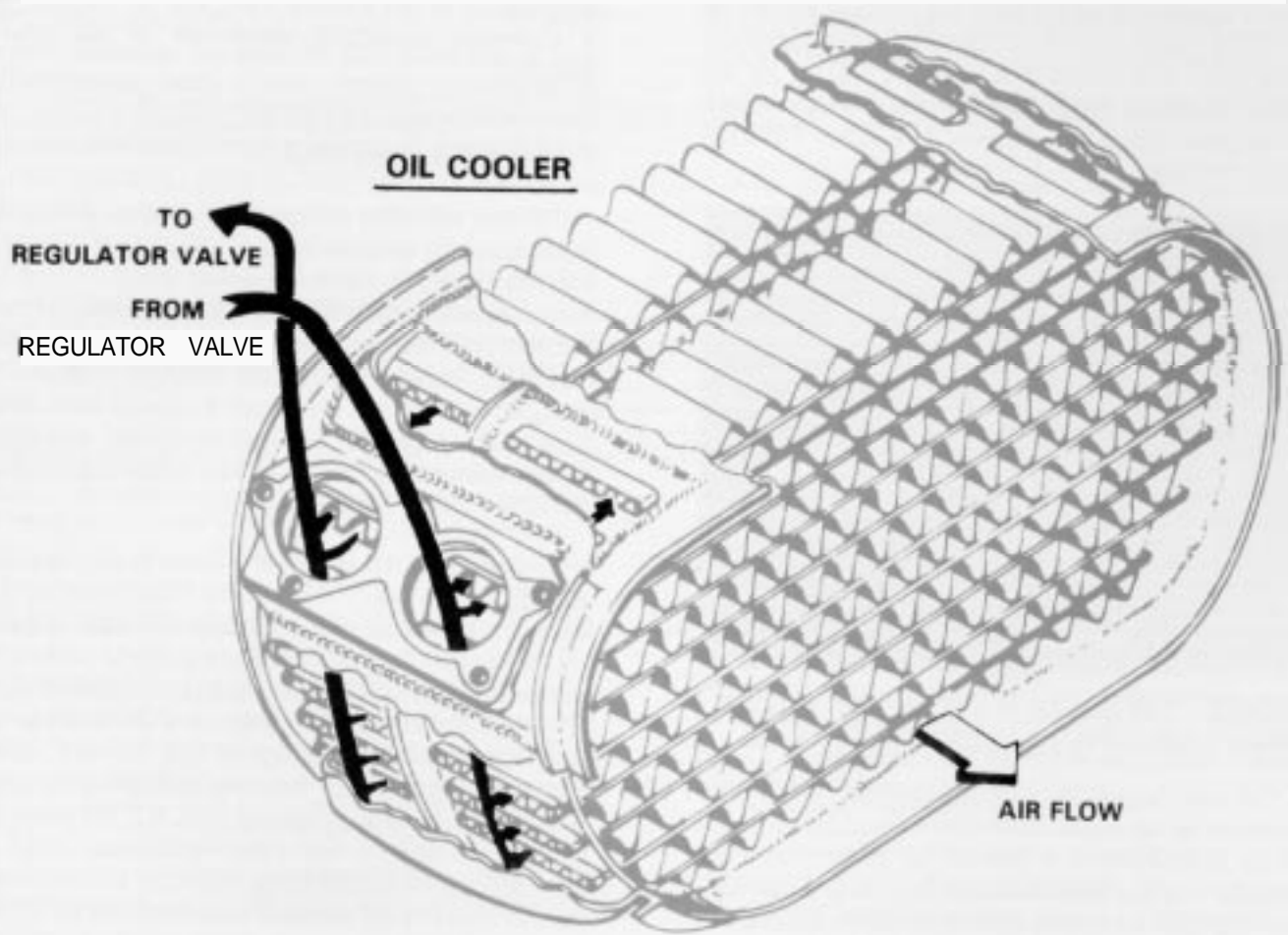
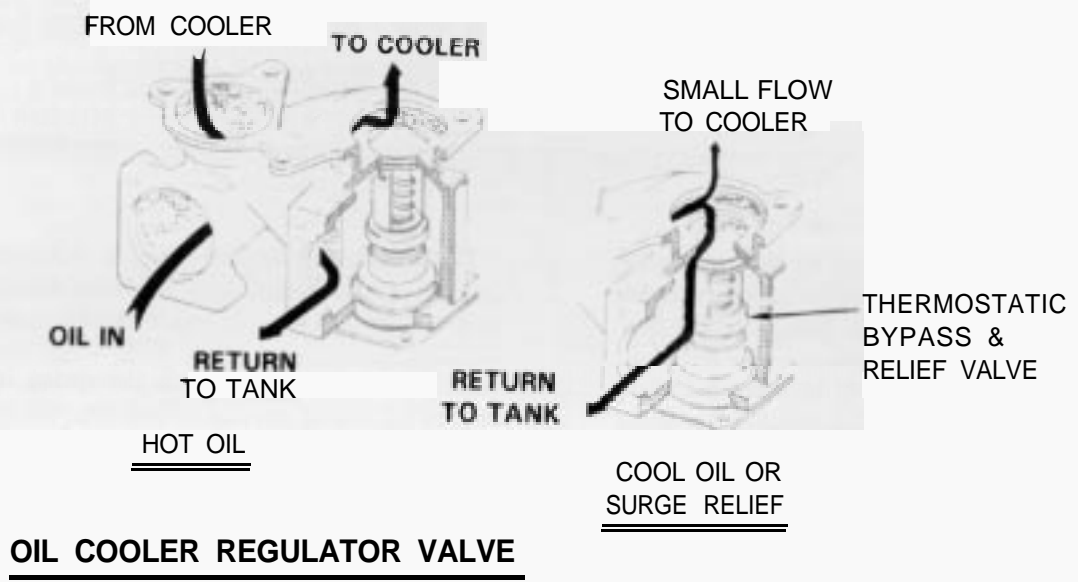
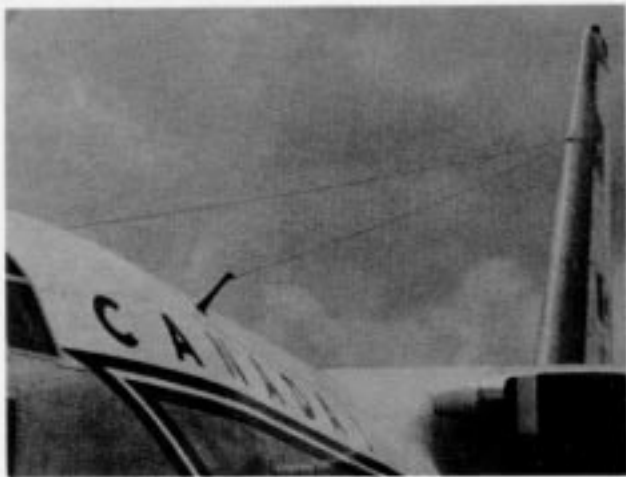

Figure 3. Oil cooler and oil cooler regulator valve detail.

# HF Antenna Wire Breakage

A broken HF antenna is at best an inconvenience; if it breaks during flight, there may be unwelcome side effects that go beyond the obvious things such as crippled communications. A loose antenna wire whipping around in the slipstream is likely to leave a trail of unsightly superficial damage on the empennage, and if it is lost from the aircraft completely, the falling wire can pose a hazard to personnel and facilities on the ground.

Two AML-61 antenna masts provide anchor points for the HF antenna wires on most Hercules aircraft. One is attached to each side of the fuselage just aft of the flight station (Figure 1). The two wires run aft from these masts and attach to a common bracket on the vertical stabilizer. When a wire breaks, it usually occurs at the point where the antenna wire enters the mast chuck assembly.



**Figure 1.** The forward end of each HF antenna wire is anchored to an AML-61 antenna mast.

The most common cause of wire failure has been shown to be corrosion. Laboratory examination of the chuck assemblies in a number of cases where the antenna wire had failed indicated that the principal corrosion product was iron oxide (rust) from the copper-coated steel antenna wire and copper-coated steel chuck spring. The stainless steel chuck assembly body and spring locating screw and the brass chuck jaws are apparently not corroding. An exploded view of the wire chuck assembly and its installation is shown in Figure 2.

Evidently, the problem begins when the copper coating of the antenna wire is broken during preparation for installation. If the wire is nicked at all, it exposes the steel core of the wire, which subsequently rusts. The copper coating on the spring is probably rubbed off during normal service use, which causes the exposed steel to rust when moisture enters the antenna mast.

Lockheed engineering recommends three steps to be taken to prevent corrosion within the antenna mast: proper assembly of the antenna mast and wire, proper preparation of the antenna wire, and the addition of a corrosion preventive compound to the chuck assembly.

## Cutting the Antenna Wire

The first step after attaching the antenna wire to the strain insulator near the vertical stabilizer is to cut the antenna to length. There are several things to consider before actually cutting the wire. Most important of these is not to cut it too short. Make full allowances and then cut. It is relatively easy to trim more off if necessary. Also, be sure that the wire is not kinked or bent. Wipe it clean and inspect for damaged insulation, embedded foreign particles, and other defects which might reduce the effectiveness of the insulation.

To determine the length of wire to be cut, unwind enough wire to reach the antenna mast, allowing for about three inches to extend into the mast. Again, remember that overestimating the length is preferable since some adjustment can be made by the tension take-up unit at the aft end of the antenna. As much as an inch can also be taken up in the forward mast. However, once the wire has been inserted in the gripping jaws of the tension take-up unit, it is not practical to remove it to gain more slack. With these things in mind and the wire pulled along beside the antenna mast, cut the wire at a point which will allow you to obtain the desired tension after installation of the antenna.

## Installation

The antenna is secured in the mast by a 1/2-inch

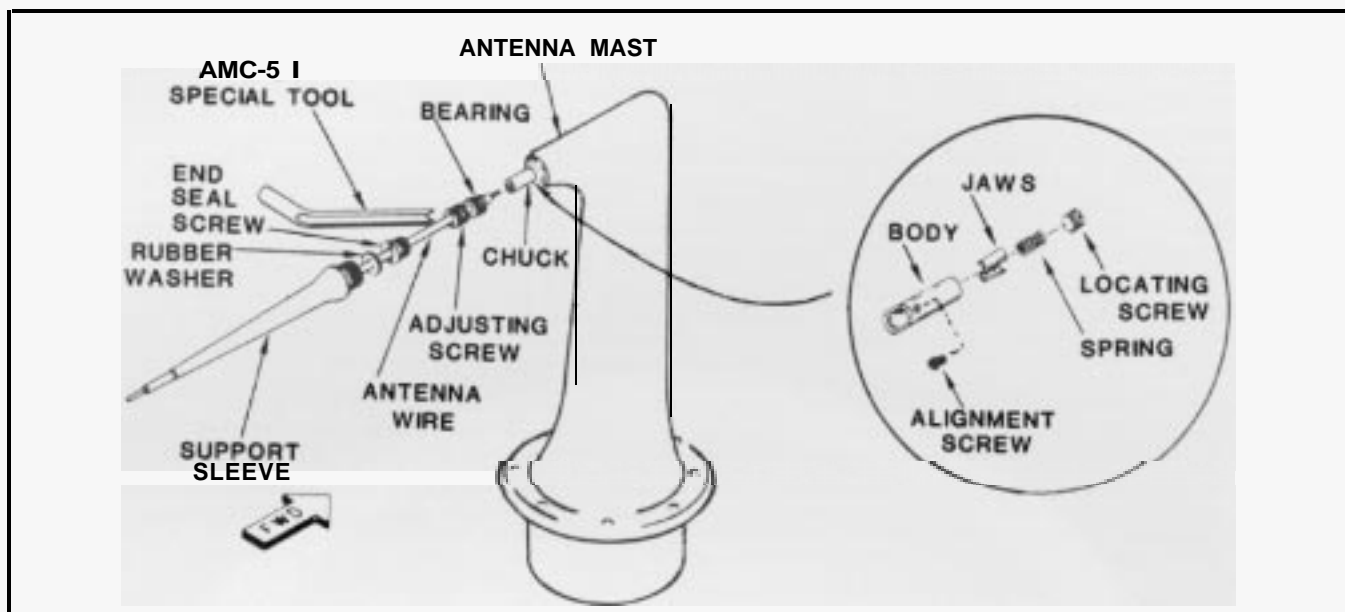

**Figure 2 AMV-61 antenna mast assembly and chuck assembly detail**

length of bare antenna conductor clamped in a spring-loaded brass chuck. Therefore, enough insulation must be removed from the end to expose a 1/2-inch length of conductor with the wire end square and free from burrs. Accurate removal of the insulation is best accomplished using a wire retriever tool made to the military standard MS251 19-1. Insert the wire end into the tool until it bottoms in the counterbore. Place a thin knife in the slot and, while applying pressure on the blade, rotate the wire one complete revolution. Remove the wire from the tool, grip the partially severed section of the insulation with pliers, and carefully twist it off. The exposed 1/2 inch length of conductor must be free from nicks, burrs, and scratches to permit free entry into the chuck assembly, and its copper coating must be intact.

Slide all of the antenna mast attaching parts (except the chuck) onto the antenna wire, as illustrated in Figure 2. They go on in this order: antenna support sleeve, rubber washer, end seal screw, and the adjusting screw. These parts should be pushed back on the wire approximately 12 inches before attaching the antenna. Slip the antenna wire bearing over the conductor and insert the full length of the bare wire conductor into the chuck assembly. Three or four sharp in-and-out motions should be made to ensure proper gripping of the conductor by the chuck jaws.

After assembly, carefully remove the locating screw on the end of the chuck assembly and fill it with corrosion preventive compound. Also, sparingly apply corrosion preventive compound to the outside junction point between the chuck jaws and antenna wire. Remove any compound that may get on the exterior of the chuck assembly so that the wire will bond electrically in the fitting when installation in the mast is complete.

Reinstall the chuck assembly locating screw. The suggested corrosion preventive compounds are listed below in order of preference: MIL-S-8660, silicone compound (Dow Corning DC-4); MIL-G-6032, plug valve grease; MIL-C-11796, Class 1, corrosion preventive compound; or MIL-C-16173, Grade 1 or 4, corrosion preventive compound.

After installation of the wire in the chuck assembly, slide the adjusting screw and bearing forward against the chuck assembly and, using special tool AMC-51, screw the adjusting screw into the antenna mast. Slide the end seal screw into the mast and tighten with special tool AMC-51. Then slide the rubber washer forward against the end seal screw and secure in place by screwing the antenna support sleeve into the antenna mast until it is finger-tight. Do not use pliers to tighten the support sleeve. Coat the tip of the support sleeve lightly with corrosion preventive compound to repel entrance of moisture where the wire enters the sleeve.

When the antenna is completely installed, that is, complete with strain insulator and tension take-up installed and antenna connected to the vertical stabilizer, additional tension may be applied to the antenna wire by screwing the adjusting screw further into the mast head. The adjusting screw will travel approximately one inch past the flush position.

As with any procedure such as this one, refer to the technical manuals before taking any action. Check the appropriate technical manual for instructions on the proper tension at the tension take-up unit. Finally, recheck both antennas for any discrepancies after the installation is complete. With careful attention to the installation procedure, there should be no problem with corrosion in the antenna wire.



 *Lockheed-Georgia Company*

CUSTOMER SERVICE  
LOCKHEED-GEORGIA COMPANY  
A Division of Lockheed Corporation  
Marietta, Georgia 30063

